

GIANFRANCO
FERRE
HOME

Available at:

PALAZZO COLLEZIONI

www.palazzocollezioni.com.au



















LIVING ROOM



YORK SOFA

Contemporary elegance and metropolitan spirit for the York sofa. Perfect for a modern and luxurious living room, the sofa recalls the business-oriented environments of the American cities.

The simplicity given by the linearity of the design is balanced by the refinement of the tailoring, that enhances the link with the world of men's fashion. The decorative inserts of the armrest and the stitching on the cylindrical legs recall the tailored suits of businessmen and their bags. The contrast between colours and materials - nubuck in a neutral and delicate shade of grey for the upholstery and dark brown saddle leather for the details - gives a strong and modern character to this ensemble with its transversal and sophisticated aesthetic.

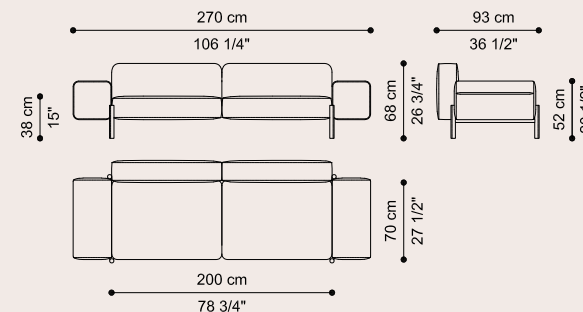

F.YOR.211.A

3-seater sofa



F.YOR.211.ABX

3-seater sofa

COMPOSITION

Sofa with structure in multilayer wood. Under-seat frame with elastic webbing that guarantees springiness.

Seat and backrest in high density expansive polyurethane foam. Upholstery in cat. B leather Nabuk L.08.04 Dove.

Armrests in multilayer wood and high density expansive polyurethane foam. Upholstery in cat. B leather Nabuk L.08.04 Dove. Decorative insert in dark brown saddle leather.

Base in cylindrical iron tubing with Black Chrome finishing.



F.ACC.871.ABX

F.ACC.884.AXX

L 45 D 45 cm
Leather NABUK
L.08.06 Brown
cat. B



F.ACC.871.ABX

L 45 D 45 cm
Leather NABUK
L.08.04 Dove
cat. B

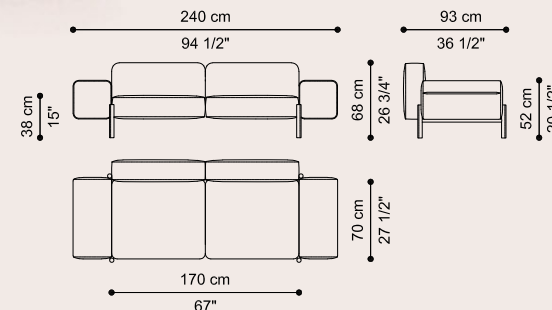

F.YOR.211.B

2-seater sofa



Leather NABUK
L.08.04 Dove
cat. B



Dark brown
saddle leather



BLACK CHROME
FINISHING

KALAMAJA ARMCHAIR/FOOT REST

Retro style and metropolitan spirit for the Kalamaja armchair and foot rest. The solid structure in wood meets the lightness of the suspended saddle leather seat, supported by the armrests with characteristic straps. Furnishing elements in typical Mid-century style that fits perfectly into urban decor environments.

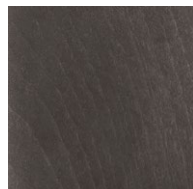

SOLID BEECH WOOD
DYED SMOKEY GREY



Black saddle leather

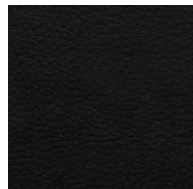

Leather NABUK
L.08.13 Black
cat. B

F.KAA.221.ABX

Armchair

F.KAA.561.ABX

Foot rest

COMPOSITION

Armchair with structure in solid beech wood dyed Smokey Grey, shaped with variable section by CNC technology, with irregular curves and finger joints. Seat and backrest in black saddle leather, with decorative stitching in nylon thread, fixed to the structure with metal buckles with gold finishing. Seat cushion padded in foam and goose down. Upholstery in leather cat. B Nabuk L.08.13 Black. Headrest cushion padded in foam and goose down. Upholstery in leather cat. B Nabuk L.08.13 Black, with contrasting embroidered logo.

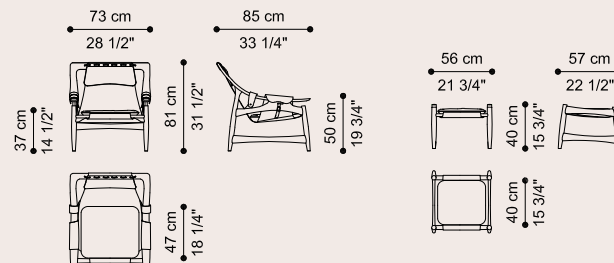

PHOENIX DAYBED

The daybed - new entry of the Phoenix line - conquers with its essential lines and vintage charm. Featuring an armrest with oval inclined section and retro-style feet with black chrome finishing, it is upholstered in dark grey fabric and embellished with decorative belts. An irresistible invitation to relax, perfect for separating two space or to complete the furnishing of the living area.



Fabric WOVEN
 19.20 Dark Grey
 cat. A



Dark brown
 saddle leather



BLACK CHROME
 FINISHING

F. PHO. 227. ACX

COMPOSITION

Daybed with structure in multilayer wood. Seat with elastic webbing that guarantees springiness. Padding in high density expansive polyurethane foam and dacron. Upholstery in fabric cat. A Woven 19.20 Dark Grey.

Armrest with padding in high density expansive polyurethane foam and dacron, with laser-cut oval inclined section.

Upholstery in fabric cat. A Woven 19.20 Dark Grey. Decorative belts in dark brown saddle leather. Metal buckle with Black Chrome finishing.

Base in metal tubing with circular section with Black Chrome finishing.

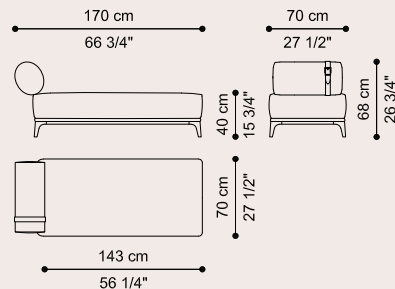

MINI POUF

The Mini pouf features a light and versatile design. Small, soft and compact, it adds character to any setting.
Available in nubuck leather or in different menswear fabrics of the collection: Pied de Poule, pinstripe, twill, Prince of Wales.



F. MIN. 561. ABX

COMPOSITION

Pouf with structure in shaped multilayer wood panels, padded in polyurethane foam and dacron.

Legs in solid beech wood with retractable pins. Upholstery in leather cat. B Nabuk L.08.06 Brown.

Seat with decorative stitching in nylon thread, in colour matching the upholstery.

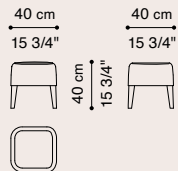

Leather NABUK
L.08.06 Brown
cat. B

DOPPLER CONSOLE

Doppler reinvents the style and function of a traditional furnishing item such as the console, lending it a bold and contemporary personality thanks to the contrast between the Tay Dyed Smokey Grey top and the light structure with cylindrical cross-sections, with black finishing. A new passe-partout, to be used as a stand-alone piece or together with other elements, the Doppler console fits with its eclectic elegance in any furnishing context.

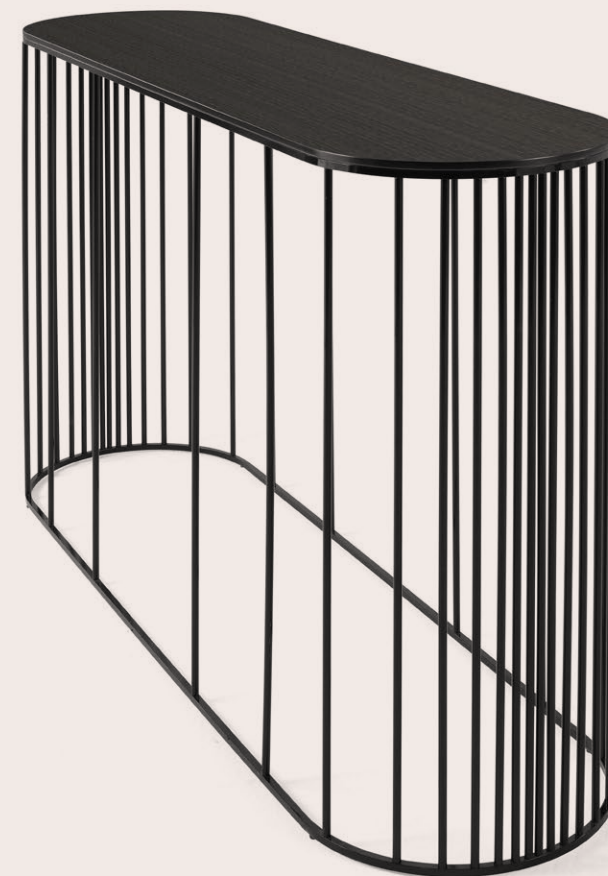
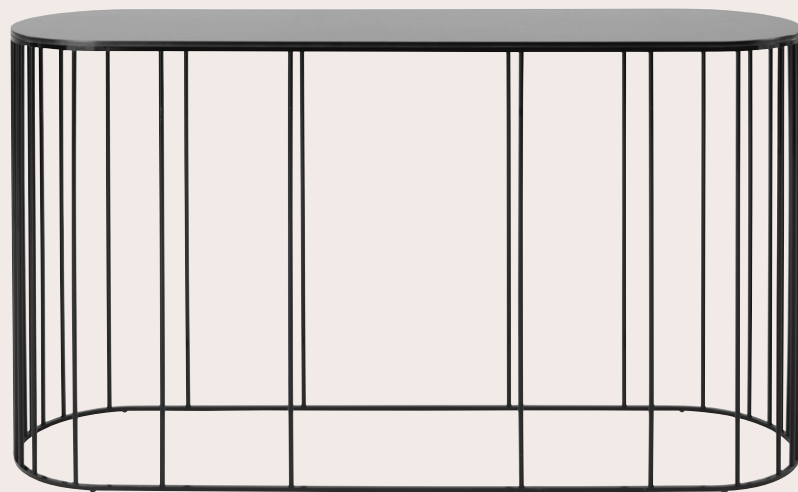

TAY VENEERED DYED
SMOKEY GREY

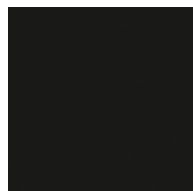

MATT BLACK FINISHING

F.DOP.541.ASX

COMPOSITION

Console with structure in metal with matt black finishing.
Top in multilayer wood Tay veneered Dyed Smokey Grey.

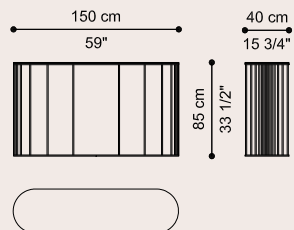

DOPPLER LOW TABLE

Versatile and eclectic, Doppler small table is characterized by a round top in multilayer wood veneered in Tay Dyed Smokey Grey, supported by a light structure with cylindrical cross-sections, with black finishing. Available in different heights and diameters, it allows the creation of fluid and functional compositions, to be inserted in a contemporary living room or bedroom.

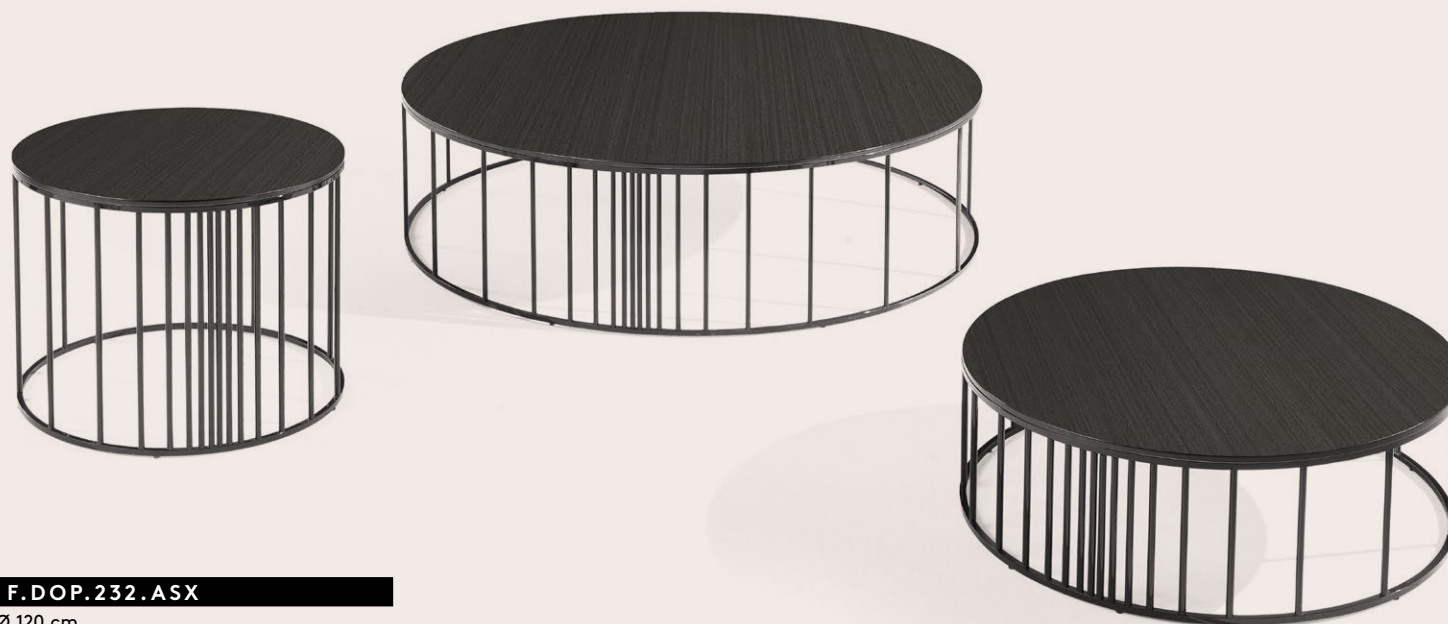

TAY VENEERED DYED
 SMOKEY GREY

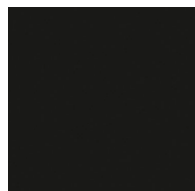

MATT BLACK FINISHING

F.DOP.232.ASX

Ø 120 cm

F.DOP.232.BSX

Ø 70 cm

F.DOP.232.CSX

Ø 54 cm

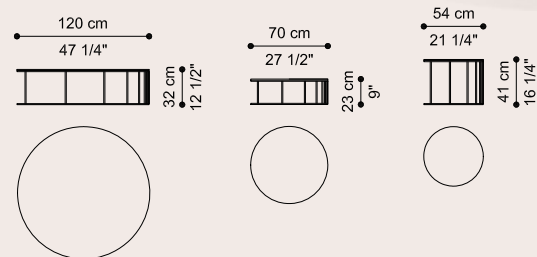

COMPOSITION

Low tables with structure in metal with matt black finishing. Top in multilayer wood Tay veneered Dyed Smokey Grey.

GRACIA LOW TABLE

A simple and refined design for the Gracia coffee table, whose cylindrical shape is enhanced by the brushed bronze finishing that lends the piece a vintage and refined charm. The combination of pieces of different sizes allows the creation of compositions with a sculptural and scenographic charm.



BRUSHED BRONZE

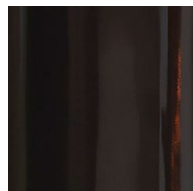

FERRÉ BLACK
LACQUERED

F.GRA.231.CLX

COMPOSITION

Cylindrical side table with structure in metal with Brushed Bronze finishing.
Base in solid beech wood with Ferré Black Lacquered finishing.

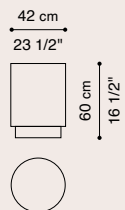

LAPA FLOOR LAMP

Inspired by 50s Mid-century modern lamps, Lapa boasts a slender design and a retro-chic charm. The shape of the shade recalling the cymbals, together with the suggestive combination of brass and black chrome finishing, helps to recreate an evocative atmosphere that recalls the classic New York jazz environments.

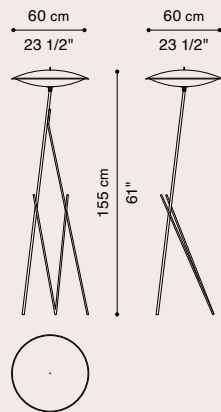

F.LAP.622.ALX

COMPOSITION

Structure in metal with black chrome finishing. Shade in white opaline glass with top in metal with black chrome finishing. Led light.



BLACK CHROME
FINISHING



DINING ROOM



ROCKEFELLER DINING TABLE

Rockefeller is an elegant dining table with a contemporary aesthetic. Its sculptural design is characterized by the contrast between solidity and lightness, stability and dynamism and light and dark shades. The robust appearance given by the thickness of the legs is counterbalanced by the delicacy and elegance of Travertino marble. The top with smoky grey finish - in contrast with the delicate tone of the legs - presents a rhomboidal decoration and has a rounded shape, to give a sense of softness to the whole.



TAY VENEERED WOOD
DYED SMOKEY GREY

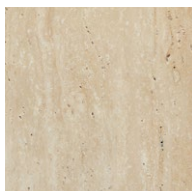

TRAVERTINO MARBLE



BLACK CHROME

F. ROC.124. AIS

COMPOSITION

Dining table with structure and lower part of the top in metal.
Cylindrical legs in Travertino marble, with metal plates in Black Chrome finishing.
Top in MDF veneered in Tay Dyed Smokey Grey, with edge in solid beech wood shaped with flared section by CNC technology.

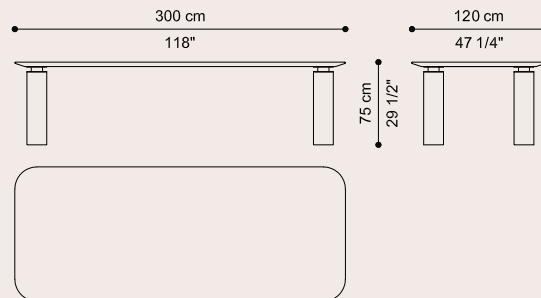

HARLEM CHAIR

A slender and light structure, with tapered legs and a dynamically shaped backrest for the Harlem chair. In the name there is a reference to the famous district of New York, renowned for its jazz clubs and historic soul clubs. The leather upholstery and the smoke grey-stained wood structure enhance its contemporary appeal, making it perfect for creating settings with a metropolitan atmosphere.

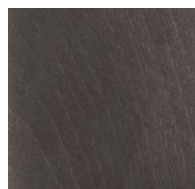

SOLID BEECH WOOD
DYED SMOKEY GREY



Leather NABUK
L.08.06 Brown
cat. B

F.HAL.132.ABX

COMPOSITION

Chair with structure in solid beech wood dyed Smokey Grey, with turned legs that connect the seat to the backrest with concealed pins.

Seat and backrest in expansive polyurethane foam. Upholstery in leather cat. B Nabuk L.08.06 Brown.

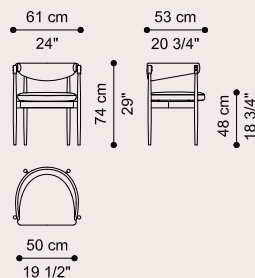

MADISON ARMCHAIR

A vintage inspiration with a revisited Brazilian style for Madison armchair. The soft and enveloping shape and the structural belts that guarantee the comfort of the seat make the armchair a relaxing piece of furniture. With its bold character, the armchair fits perfectly into environments with metropolitan and contemporary atmospheres.

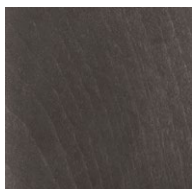

SOLID BEECH WOOD
 DYED SMOKEY GREY



Leather NABUK
 L.08.04 Dove
 cat. B

F. MAI.221.ABX

COMPOSITION

Armchair with structure in solid beech wood dyed Smokey Grey, shaped in variable section by CNC technology. Structural belts in saddle leather, that guarantee the comfort of the seat. Seat and backrest with padding in variable thickness high density expansive polyurethane foam, fixed to the structure with belts and buckles. Upholstery in leather cat. B Nabuk L.08.04 Dove.

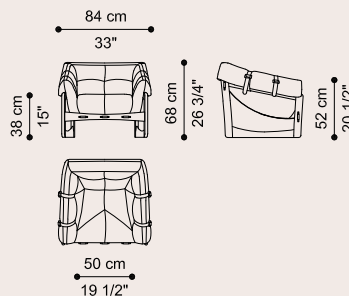

NEW ORLEANS CABINET

The cabinet completes the New Orleans line by combining aesthetics and functionality. Characterized by a gres porcelain back with Calacatta design, paired with smoked glass, it is equipped with a technology that allows the LED inserted in the showcase to be switched on simply by approaching the base, allowing an intimate and refined lighting.



TAY VENEERED DYED
 SMOKEY GREY



SMOKED GLASS

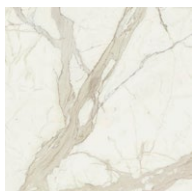

CALACATTA MAXIMUM
 PORCELAIN GRES



BLACK CHROME

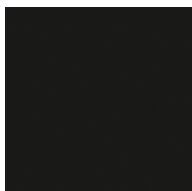

MATT BLACK



F.NOS.112.ASX

COMPOSITION

Cabinet with structure in multilayer wood veneered in Tay dyed Smokey Grey, assembled at 45° with 25x10 mm tubular insert in steel with Black Chrome finishing, with retractable handles and pins. Doors in 8 mm thick smoked tempered glass. Handles in electro welded steel with Black Chrome finishing. Backrest in multilayer wood, with internal cover in Calacatta Maximum porcelain gres and external cover in black microfibre. Internal lighting system with activation through motion sensor located on the right side of the base controlling the switching on of natural LED lighting. Base in multilayer wood lacquered matt black.

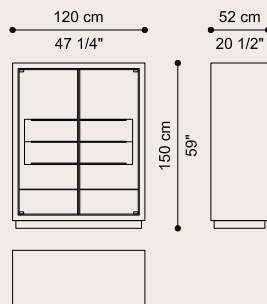

NEW ORLEANS SIDEBOARD

A functional element with a high aesthetic and semantic value, in line with the eclectic spirit that permeates Gianfranco Ferré Home collection, the New Orleans sideboard winks at the world of music by offering its tribute to the capital of Jazz. The black chromed profiles emphasize the volume of the structure in fine Tay wood dyed Smokey Grey, creating a design that recalls the keyboard of a musical instrument.



TAY VENEERED DYED
 SMOKEY GREY



BLACK CHROME

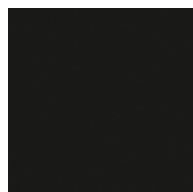

MATT BLACK

F. NOS. 114 . ASX

COMPOSITION

Sideboard with structure in multilayer wood veneered in Tay dyed Smokey Grey, assembled at 45° with 25x10 mm tubular insert in steel with Black Chrome finishing, with retractable handles and pins. Drawers in multilayer wood veneered in Tay dyed Smokey Grey. Drawer rails with soft closing. Handles in steel with Black Chrome finishing. Backrest in multilayer wood covered in black microfibre. Base in multilayer wood lacquered matt black.

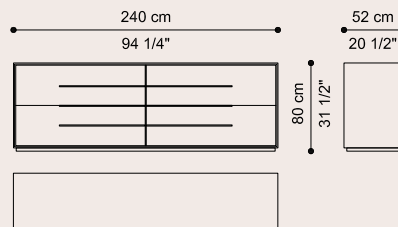

QUEENS LOW TABLE

Minimalism and essentiality for the Queens coffee table, characterized by a metal frame and top with black chromed finishing or bronzed finishing with base in precious Black Marquinia marble.



BRUSHED BRONZE

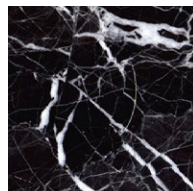

BLACK MARQUINIA
MARBLE

F.QEE.231.A1L

COMPOSITION

Side table with base in Black Marquinia marble, shaped like a truncated cone. Central cylindrical support in iron with Brushed Bronze finishing. Top in iron with Brushed Bronze finishing.



ROOSEVELT STANDING MIRROR

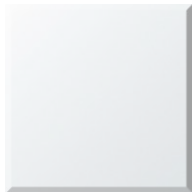

NATURAL MIRROR

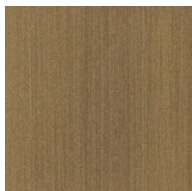

BRUSHED BRONZE

F. ROV. 524 . AHX

COMPOSITION

Standing mirror with frame in iron with Brushed Bronze finishing.
MDF panel with wall hooks on the back.
Natural mirror.

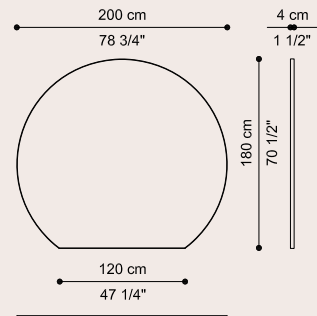

MALASANA CHANDELIER

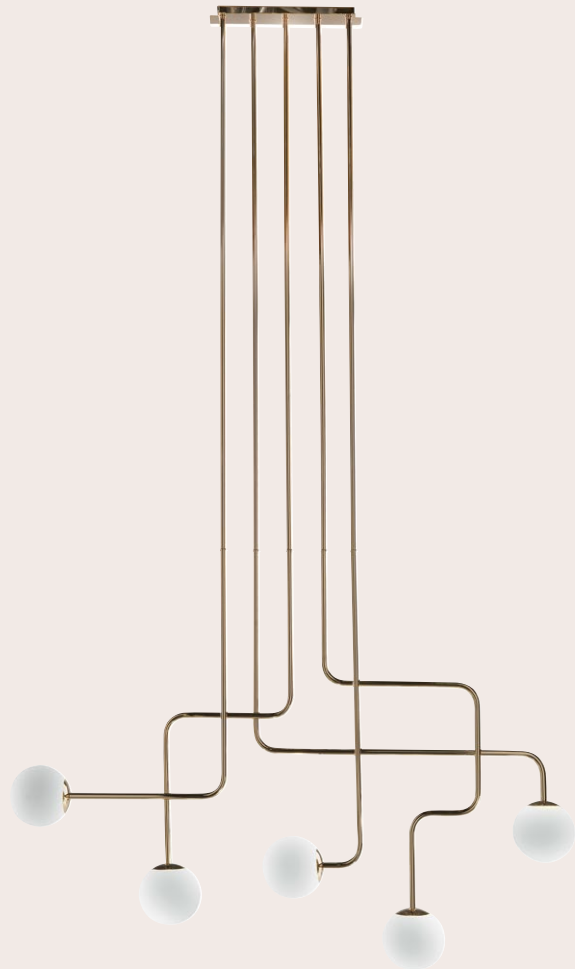

POLISHED BRASS

F. MAL. 615. AYX

COMPOSITION

5-light chandelier with rectangular ceiling rose. Cylindrical metal tubes. Shades in white satin glass. LED lights.

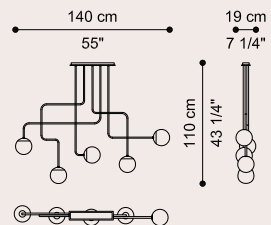

STUARDA FLOOR LAMP



F.STD.622.ALX

COMPOSITION

Cylindrical floor lamp with base in iron with Brushed Dark Bronze finishing. Shade in fabric with bar in glossy brass. LED light.

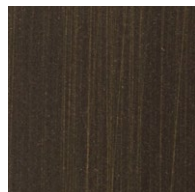
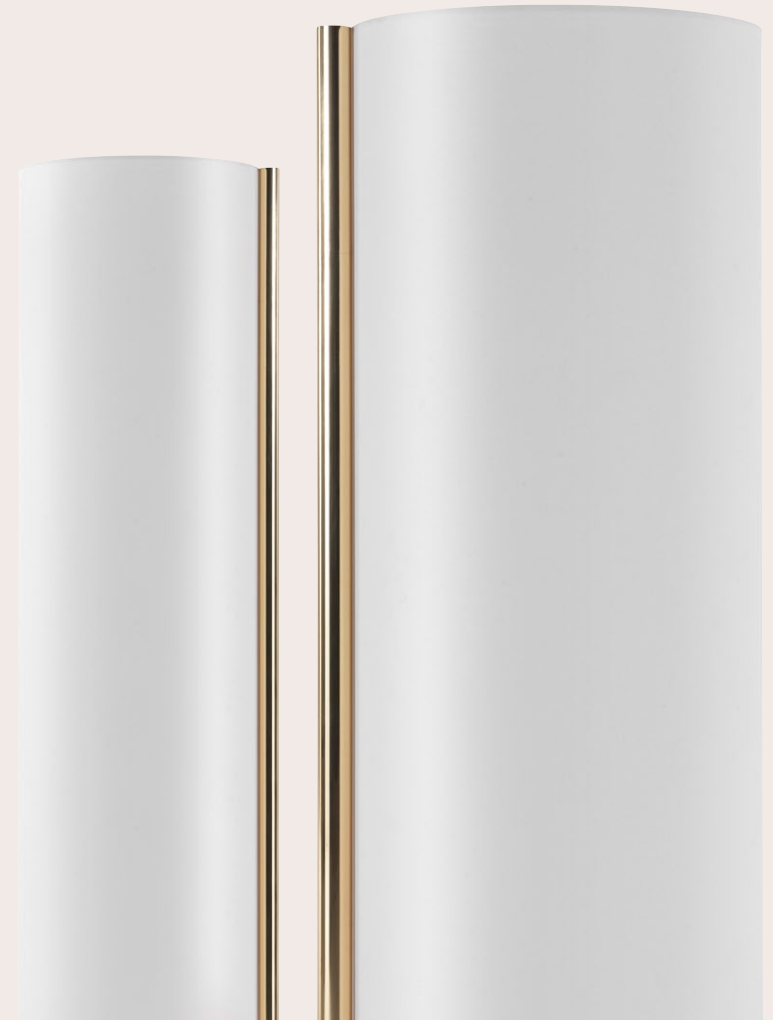
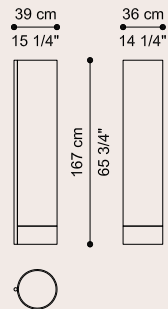

BRUSHED DARK BRONZE

BULB TABLE LAMP



F. BUL. 632. AMX

COMPOSITION
Table lamp with cylindrical base in chrome finishing. Natural glass shade. Analogue light bulb.

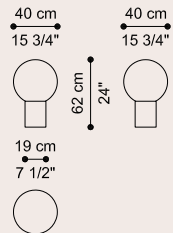

CHROME

BEDROOM



MALCOLM BED

Malcolm is a bed with a refined aesthetic, able to lend the sleeping area a welcoming and sophisticated appeal. Perfect in proportions, Malcolm stands out for its linear and contemporary design that matches aesthetic and functional details. The leather covering headboard and bed frame amplifies the feeling of comfort and relaxation, while the neutral and delicate shades of the bed are in line with the mood of the collection.



Fabric HEAVY
CHENILLE 16.03 Beige
cat. A



Leather NABUK
L.08.04 Dove
cat. B

F.MCM.315.ACX + F.MCM.316.ABX

Outer headboard

Inner headboard + bed frame

COMPOSITION

Bed with headboard composed of two volumes at different heights in solid wood and expansive polyurethane foam. External part upholstered in fabric cat. A Heavy Chenille 16.03 Beige. and internal part in leather cat. B Nabuk L.08.04 Dove. Bed frame in solid wood and expansive polyurethane foam, upholstered in leather cat. B L.08.04 Dove.

Recessed bed base with lifting mechanism for use of the storage box.

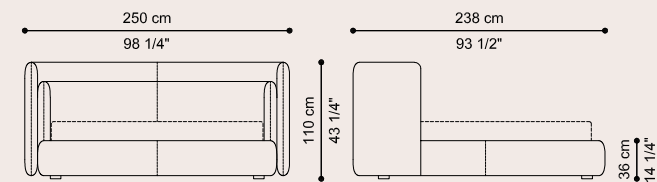

F.MCM.315.B

Bed for mattress 200 x 200 cm
Outer headboard

F.MCM.316.B

Bed for mattress 200 x 200 cm
Inner headboard + bed frame

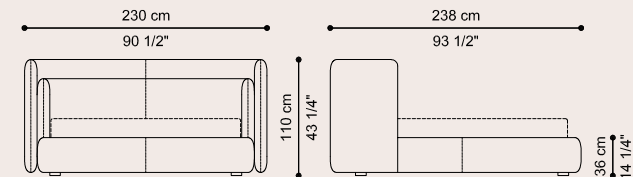

F.MCM.315.A

Bed for mattress 180 x 200 cm
Outer headboard

F.MCM.316.A

Bed for mattress 180 x 200 cm
Inner headboard + bed frame

NEW ORLEANS NIGHT TABLE

Essentiality is enriched with new symbolic meanings in the night table of the New Orleans line. The metal details illuminate the linear volume of the structure in fine wood essence and recreate a geometric design that recalls the keyboard of stringed instruments, confirming the link with the world of music already evoked by the name: a tribute to the "capital of Jazz", birthplace of Louis Armstrong.



TAY VENEERED DYED
 SMOKEY GREY



BLACK CHROME

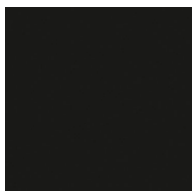

MATT BLACK



F. NOS. 331. ASX

COMPOSITION

Night table with structure in multilayer wood veneered in Tay dyed Smokey Grey, assembled at 45°. Internal perimeter of the steel structure with Black Chrome finishing, with 25 x 10 mm decorative tubular insert.

Two drawers with handles in 25 x 10 mm steel tubing with Black Chrome finishing. Inner cover in black microfibre.

Base in multilayer wood varnished matt black.

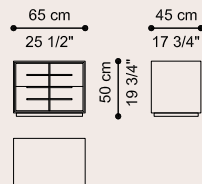

NEW ORLEANS DRAWER UNIT

A functional element with a high aesthetic and semantic value, in line with the eclectic spirit that permeates the collection, the New Orleans chest of drawers winks at the world of music by offering its tribute to the capital of Jazz. The metal profiles emphasize the volume of the structure in fine wood essence, creating a design that recalls the keyboard of a musical instrument.



TAY VENEERED DYED
 SMOKEY GREY



BLACK CHROME

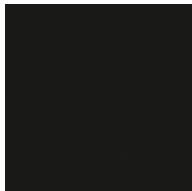

MATT BLACK

F.NOS.322.ASX

COMPOSITION

Drawer unit with structure in multilayer wood veneered in Tay dyed Smokey Grey, assembled at 45°. Internal perimeter of the steel structure with Black Chrome finishing, with 25 x 10 mm decorative tubular insert.

Three drawers with handles in 25 x 10 mm steel tubing with Black Chrome finishing. Inner cover in black microfibre.

Base in multilayer wood varnished matt black.

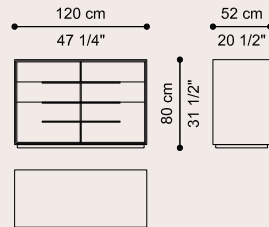

F.NOS.322.A

Drawer unit - 3 drawers

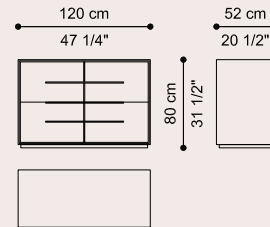

F.NOS.321.A

Drawer unit - 2 drawers



MALCOLM SOFA

Malcolm is a sofa with a refined aesthetic, the perfect protagonist of welcoming and sophisticated living areas. Perfect in proportions, Malcolm stands out for its original design with backrest composed of two volumes at different heights. The aesthetic and functional details amplify the feeling of comfort and relaxation, first of all the use of leather. The neutral and delicate shades of the sofa are in line with the mood of the collection.



Fabric HEAVY
 CHENILLE 16.03 Beige
 cat. A



Leather NABUK
 L.08.04 Dove
 cat. B

F.MCM.211.ABX + F.MCM.801.AXX

2-seater sofa Internal cushions

COMPOSITION

Sofa with backrest composed of two volumes at different heights in solid wood and expansive polyurethane foam. External part upholstered in leather cat. B Nabuk L.08.04 Dove and internal part and two backrest cushions in fabric Heavy Chenille cat. A 16.03 Beige. Seat in solid beech wood and variable thickness high density expansive polyurethane foam, with elastic webbing that guarantees springiness.

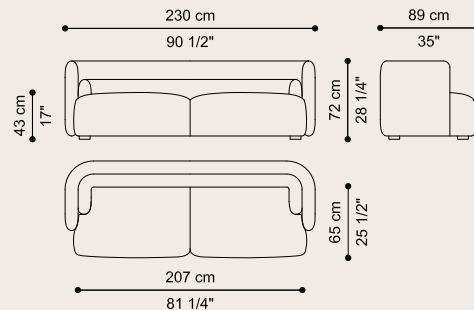

MARVILA ARMCHAIR

Retro taste and soft and rounded shapes for the Marvila armchair. The refined elegance and compact proportions are enhanced by the base with bronzed finishing, a detail that gives the whole a sophisticated decorative appeal.



Leather NABUK
 L.08.04 Dove
 cat. B

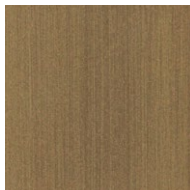

BRUSHED BRONZE
 LACQUERED

F.MAV.221.BBX

COMPOSITION

Armchair with structure in shaped solid beech wood and multilayer wood. Padding in expansive polyurethane foam and dacron. Upholstery in leather cat. B Nabuk L.08.01 Sand and external back rest in leather cat. B Nabuk L.08.04 Dove. Base in solid beech wood in brushed bronze lacquered finishing.
 Optional swivel base.

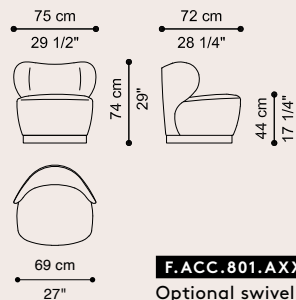

F.ACC.801.AXX

Optional swivel base

BROOKLYN POUF

A pouf with an eclectic and versatile elegance, Brooklyn boasts fine sartorial details and is enriched with decorative leather belts. Perfect to be placed in the bedroom, the pouf is equally at home in residential or public settings, individually or in bespoke combinations.

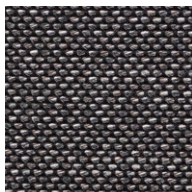

Fabric **WOVEN**
19.20 Dark Grey
cat. A

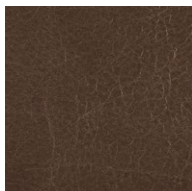

DARK BROWN SADDLE
LEATHER

F.BRY.561.BCX

COMPOSITION

Pouf with structure in MDF, variable thickness high density expansive polyurethane foam and dacron. Upholstery in fabric cat. A Woven 19.20 Dark Grey. Decorative belts in dark brown saddle leather, with decorative stitching in nylon thread.

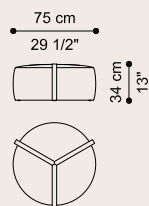

LOWERY LOW TABLE

Essential lines and contemporary appeal for Lowery coffee tables. Characterized by a double round top and a light and dynamic structure, they are the ideal complements for an intimate, functional and welcoming space.



GLOSSY BLACK

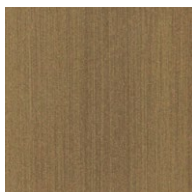

BRUSHED BRONZE

F.LOW.231.BLX **F.LOW.231.CLX** **F.LOW.232.ALX**

Side table h. 50

Side table h. 40

Central table h. 30

COMPOSITION

Structure in iron. Legs with round section with Glossy Black finishing. Upper top in metal with Glossy Black finishing. Lower top available in different metal finishings.

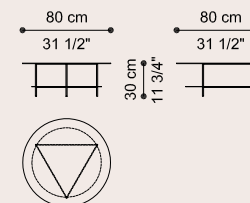
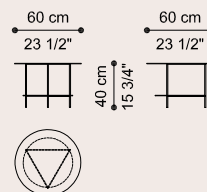
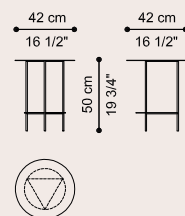

CARROLL_2 MIRROR

Function and simple elegance are combined in the Carrol_2 mirror. Thanks to its minimalist design and round shape, the mirror easily fit with furniture of any style.

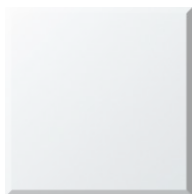
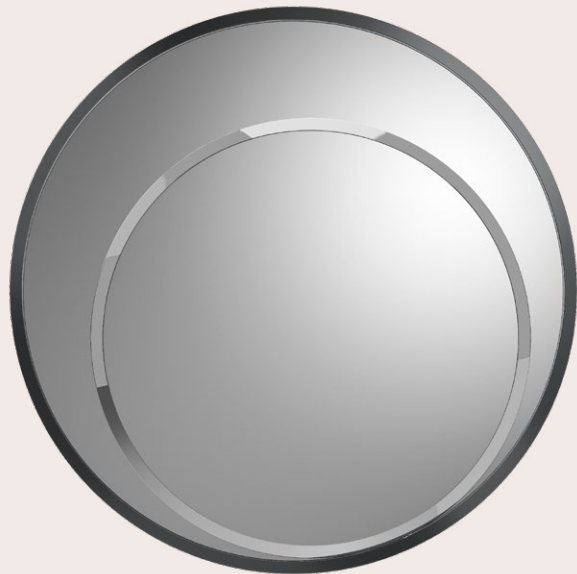

NATURAL MIRROR



BLACK CHROME

F.CR2.521.AHX

COMPOSITION

Mirror with frame in 25 x 25 mm calendered iron tubing with Brushed Bronze finishing.
Panel in MDF, covered in microfibre on the back, with wall hooks.
Two natural bevelled mirrors with different diameters.

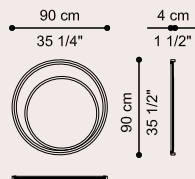

BUBBLE TABLE LAMP



F.BLE.632.ALX

COMPOSITION
Table lamp with structure in steel.
Shade in opaline glass. LED light.

